

BANDMA®

STRAPPING MACHINE

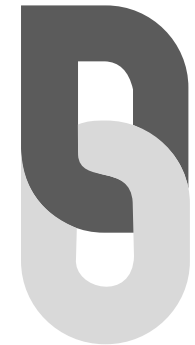
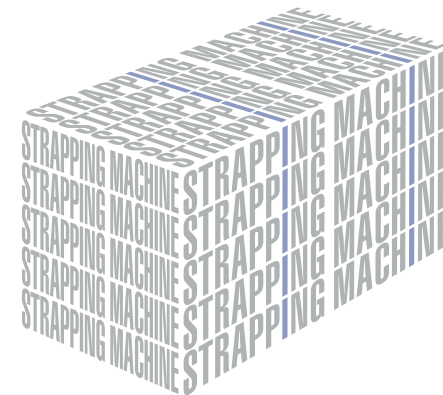

Unity, Strength & Collaboration

BANDMA EQUIPCORP LIMITED

Add. FERDEPLEX, A-16, Swarn Park Extention,
Mundka Industrial Area, New Delhi - 110041

Tel : +91-11-45518758 / +91-9205695561

Toll Free : 1800-309-2980

CIN No. : U29195DL2019PLC359096 | **GST No. :** 07AAICB8160H1ZK]

www.bandmainfo.com
contact@bandmainfo.com

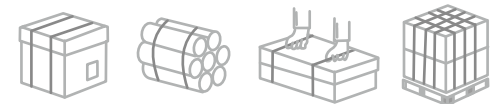

ABOUT BANDMA

Founded in 1993, **BANDMA** has been pioneering packaging and warehouse automation for over three decades. What started as a vision to revolutionize packaging has today grown into a global automation company, trusted by 2000+ satisfied clients across India and worldwide.

With a robust infrastructure spread across 100,000 sq. ft. in India, **BANDMA** houses state-of-the-art manufacturing, R&D, and service facilities that power our ability to deliver solutions that are smart, reliable, and built for scale.

From high-performance packaging machinery to end-to-end warehouse automation systems, we empower businesses to achieve greater efficiency, reduced costs, and future-ready supply chains.

Our journey of more than 30 years is driven by engineering excellence, innovation, and customer trust. With a passionate team, global presence, and a strong legacy, **BANDMA** is not just building machines—we are building the future of automation.

Our main products: strapping machine, carton sealer, pallet wrapper, vacuum machine, shrink machine, robot palletizer, robot packer, flow packer, labeling machine, filling machine and custom-made packing line.

BANDMA, As a drafting unit of national standard Bandma involves 8 industries

1. traditional packing machines
2. packing materials
3. packing solution for food and dairy industry
4. packing solution for beverage industry
5. packing solution for pharmaceuticals industry
6. packing solution for chemical industry
7. packing solution for cosmetic industry
8. software for Smart factories



PRODUCTS CATALOGUE



BDM-A31	New generation of semi-automatic strapping machine	01
BDM-A21	Semi-automatic strapping machine	03
BDM-5115(X)	High speed automatic strapping machine	05
BDM-3115	Automatic strapping machine	07
BDM-3115P	Automatic strapping machine with top presser	09
BDM-5115B	High speed fully automatic strapping machine	11
BDM-3115B	Fully automatic strapping machine	13
BDM-5115BP	High speed fully automatic strapping machine with top presser	15
BDM-3115BP	Fully automatic strapping machine with top presser	17
BDM-3115R	Fully automatic strapping machine	19
BDM-5115S	High speed automatic strapping machine (Side)	21

BDM-A31S	Stainless steel semi-automatic strapping machine	23
BDM-3115RP+YS-LX51111	Corrugated bundle squaring & strapping system	25
BDM-3115RPD+BDM-LX51111	Corrugated bundle squaring & strapping system	27
BDM-3115RP+YS-LX51111D	Corrugated bundle squaring & strapping system	29
BZ-1115A	Fully automatic horizontal strapping machine	31
BZ-1115AH	Fully automatic horizontal strapping machine(Heavy)	33
BZ-1115B	Fully automatic vertical strapping machine	35
BZ-1115BH	Fully automatic vertical strapping machine(Heavy)	37
BZ-1115C	Fully automatic vertical strapping machine with top presser	39
	Fully automatic packing line 1	41
	Fully automatic packing line 2	43
	Fully automatic packing line 3	44
BDAG12	Automatic banding machine	45
BDAG13	Automatic banding machine	47



Packaging materials	49
---------------------	----

MACHINERY CHAPTER



BDM-A31

NEW GENERATION OF SEMI-AUTOMATIC STRAPPING MACHINE

BDM-A31F ↓



Application:

It's the ideal solution for strapping cartons or bundling products with PP strap. High reliability, easy to operation, easy to maintenance.

Features:

- Compact strapping head (change to the square cutter, the heating plate widen to 20mm)
- New generation of the PCB program



BDM-A31C (closed)



BDM-A31H (H type)



BDM-A31L (low table)

BDM-A31F

SPECIFICATION

- ▲ **Power Supply:** 110V, 220V, 230V 50/60Hz 1 PH 0.35 kW
- ▲ **Tension Range:** 3~45 kg **Packing Speed:** ≤3 seconds/strap
- ▲ **Applicable PP Strap:** Width 5~15 mm, Thickness 0.5~0.85 mm
- ▲ **Applicable PP Strap Spool:** Inner dia. 200~210mm, Outer dia. 400~500 mm, Width 160~190 mm
- ▲ **Working Table Height:** 750 mm (Optional 750~920 mm adjustable)
- ▲ **Machine Dimension:** L840 × W545 × H750 mm **N.W:** 70 kg
- ▲ **Packing Measurement:** L860 × W550 × H840 mm **G.W:** 80 kg

BDM-A21

SEMI-AUTOMATIC STRAPPING MACHINE

BDM-A21F ↓



Features:

- Compact strapping head (circular cutter, the width of heating plate is 15mm)
- Soft strapping, tension range 3-45kg
- 24V DC motor; with main power switch, the safety switch is optional
- Heating head with transformer is optional, can extend the usage life
- Hinged cover plate, easy to operation



BDM-A21C (closed)



BDM-A21H (H type)



BDM-A21L (low table)

BDM-A21F

SPECIFICATION

- ▲ **Power Supply:** 110V, 220V, 230V 50/60Hz 1PH 0.25 kW
- ▲ **Tension Range:** 3-45kg **Packing Speed:** <3seconds/strap
- ▲ **Applicable PP Strap:** Width 5-15 mm, Thickness 0.5-0.85 mm
- ▲ **Applicable PP Strap Spool:** Inner dia. 200-210 mm, Outer dia. 400-500 mm, Width 160-190 mm
- ▲ **Working Table Height:** 750 mm (optional 750-920 mm adjustable)
- ▲ **Machine Dimension:** L840 × W545 × H750 mm **N.W:** 70 kg
- ▲ **Packing Measurement:** L860 × W550 × H840 mm **G.W:** 80 kg

BDM-5115(x)

HIGH SPEED AUTOMATIC STRAPPING MACHINE



BDM-5115N (internal dispenser)



BDM-5119



BDM-5112

Arch Size mm (✓ is optional)

BDM-5115(x) BDM-5115N, YS-5119 (5, 6, 9 mm PP Strap)

H \ W	650	850	1050	1250	1650
400	✓	✓			
500	standard	✓		✓	✓
600		✓		✓	
800		✓	✓	✓	
1000			✓	✓	

BDM-5112 (12 mm PP Strap)

H \ W	650	850	1050	1250	1650
400		✓			
500	standard				✓
600		✓	✓	✓	
800		✓	✓	✓	
1000		✓	✓	✓	

Optional:



Features:

- Speed up to 75cycles/min
- PLC control
- DC brushless motor
- Toolless maintenance
- Turntable operating touch screen, fault warning function
- Operation plate with sensor
- Independent dispenser release switch, easy to feed strap
- Working table adjustable: 850-950 mm



BDM-5115(x)

SPECIFICATION

- ▲ **Power Supply:** 110V, 220V, 230V 50/60Hz 1PH 0.6kW
- ▲ **Tension Range:** 0-45 kg **Packing Speed:** 75 cycles/min
- ▲ **Applicable PP Strap:** Width 5 mm, 6 mm, Thickness 0.5-0.8 mm
- ▲ **Applicable PP Strap Spool:** Inner dia. 200-210mm, Outer dia. 400-450mm, Width 170-190mm
- ▲ **Working Table Height:** 850-950 mm adjustable
- ▲ **Machine Dimension:** L1170 × W585 × H1450mm **N.W:** 185 kg (arch size 650 × 500 mm)
- ▲ **Packing Measurement:** L1220 × W650 × H1600 mm **G.W:** 230 kg (arch size 650 × 500 mm)

BDM-3115

AUTOMATIC STRAPPING MACHINE



BDM-3115N (internal dispenser)



BDM-3119



BDM-3112

Strapping & Sealing Combination

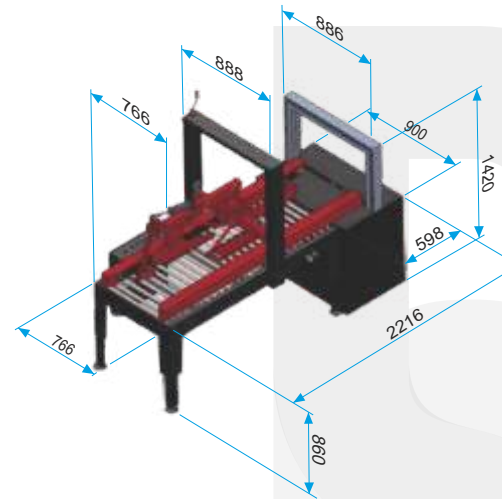

Arch Size mm (✓ is optional)

BDM-3115, BDM-3115N, BDM-3119 (5, 6, 9mm PP Strap)

H \ W	550	650	850	1050	1250	1650
400	standard (BDM-3115N only)		✓			
500		standard	✓		✓	✓
600			✓			
800			✓	✓	✓	
1000				✓	✓	

BDM-312 (12mm PP Strap)

H \ W	650	850	1050	1250	1650
400		✓			
500	standard				✓
600		✓	✓	✓	
800		✓	✓	✓	
1000		✓	✓	✓	

Features:

- Speed 50cycles/min
- DC motor
- Auto strap feeding, auto strap ejector
- Foot switch and button strapping



BDM-3115

SPECIFICATION

- ▲ **Power Supply:** 110V, 220V, 230V 50/60Hz 1PH 0.6kW
- ▲ **Tension Range:** 0~45 kg
- ▲ **Packing Speed:** 50 cycles/min
- ▲ **Applicable PP Strap:** Width 5mm~6mm, Thickness 0.5~0.8 mm
- ▲ **Applicable PP Strap Spool:** inner dia.200 210mm outer dia.400 450mm width170 190mm
- ▲ **Working Table Height:** 850mm
- ▲ **Machine Dimension:** L1170xW585xH1450mm
- ▲ **N.W:** 185 kg (arch size 650 × 500mm)
- ▲ **Packing Measurement:** L1220xW650xH1600mm
- ▲ **G.W:** 230 kg (arch size 650 × 500mm)

BDM-3115P

AUTOMATIC STRAPPING MACHINE WITH TOP PRESSER



BDM-3115P

BDM-5115P (high-level configuration is optional)

Arch Size mm (✓ is optional)

BDM-3115P, BDM-3119P, BDM-5115P, BDM-5119P
(5mm, 6mm, 9mm PP Strap)

H \ W	550	650	850	1050	1250	1650
400			✓			
500			✓		standard	✓
600			✓			
800			✓	✓	✓	
1000				✓	✓	

BDM-3112P, BDM-5112P (12 mm PP Strap)

H \ W	650	850	1050	1250	1650
400		✓			
500				standard	✓
600		✓	✓	✓	
800		✓	✓	✓	
1000		✓	✓	✓	

Features:

- Speed 40 cycles/min
- Auto strap feeding, auto strap ejector



BDM-3115P

SPECIFICATION

- ▲ **Power Supply:** 110V, 220V, 230V 50/60Hz 1PH, 220V, 380V, 400V 50/60Hz 3PH 1.0kW
- ▲ **Tension Range:** 0-45kg
- ▲ **Applicable PP Strap:** Width 5mm-6mm, Thickness 0.5-0.8 mm
- ▲ **Applicable PP Strap Spool:** Inner dia. 200-210mm, Outer dia. 400-450mm, Width 170-190 mm
- ▲ **Working Table Height:** 850mm
- ▲ **Machine Dimension:** L1500 × W585 × H1970mm **N.W:** 220 kg (arch size 1250 × 500mm)
- ▲ **Packing Measurement:** L1600 × W800 × H2100mm **G.W:** 280 kg (arch size 1250 × 500mm)

BDM-5115B

HIGH SPEED FULLY AUTOMATIC STRAPPING MACHINE



Arch Size mm (✓ is optional)

BDM-5115B, BDM-5119B (5, 6, 9mm PP Strap)

H \ W	650	850	1050	1250	1650
400		✓			
500	standard	✓		✓	✓
600		✓			
800		✓	✓	✓	
1000			✓	✓	

YS-512B (12mm PP Strap)

H \ W	650	850	1050	1250	1650
400		✓			
500	standard				✓
600		✓	✓	✓	
800		✓	✓	✓	
1000		✓	✓	✓	

Features:

- Speed up to 65cycles/min
- DC brushless motor
- Toolless maintenance
- Belt transport
- Touch screen, fault warning function
- Operation plate with sensor
- Independent dispenser release switch,easy to feed strap



BDM-5119B

BDM-5112B

BDM-5115BD
(double dispensers)

BDM-5115BL (low table)

BDM-5115B

SPECIFICATION

- ▲ **Power Supply:** 110V, 220V, 230V 50/60Hz 1PH 1.0kW, 220V, 380V, 400V 50/60Hz 3PH 1.0kW
- ▲ **Tension Range:** 0~45 kg
- ▲ **Applicable PP Strap:** Width 5mm-8mm, thickness 0.5-0.8 mm
- ▲ **Applicable PP Strap Spool:** Inner dia. 200~210mm, Outer dia. 400~450mm, Width 170~190 mm
- ▲ **Working Table Height:** ≥850mm
- ▲ **Machine Dimension:** L1480 × W730 × H1480mm
- ▲ **Packing Measurement:** L1600 × W800 × H1600mm
- ▲ **Packing Speed:** 65 cycles/min
- ▲ **N.W:** 240 kg (arch size 650 × 500mm)
- ▲ **G.W:** 280 kg (arch size 650 × 500mm)

BDM-3115B

FULLY AUTOMATIC STRAPPING MACHINE



BDM-3119B



BDM-3112B

Arch Size mm (✓ is optional)

BDM-3115B, BDM-3119B (5, 6, 9mm PP Strap)

H \ W	650	850	1050	1250	1650
400		✓			
500	standard	✓		✓	✓
600		✓			
800		✓	✓	✓	
1000			✓	✓	

BDM-3112B (12 mm PP Strap)

H \ W	650	850	1050	1250	1650
400		✓			
500	standard				✓
600		✓	✓	✓	
800		✓	✓	✓	
1000		✓	✓	✓	

Features:

- Speed 40 cycles/min
- Belt transport
- DC brush motor
- Auto strap feeding, auto strap ejector

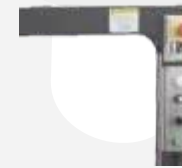

BDM-3115B

SPECIFICATION

- ▲ **Power Supply:** 110V, 220V, 230V 50/60Hz 1PH 1.0kW, 220V, 380V, 400V 50/60Hz 3PH 1.0kW
- ▲ **Tension Range:** 0~45 kg
- ▲ **Applicable PP Strap:** Width 5 mm~6 mm, Thickness 0.5~0.8 mm
- ▲ **Applicable PP Strap Spool:** Inner dia. 200~210mm, Outer dia. 400~450mm, Width 170~190mm
- ▲ **Working Table Height:** ≥850mm
- ▲ **Machine Dimension:** L1480 × W730 × H1480mm
- ▲ **Packing Measurement:** L1600 × W800 × H1600mm
- ▲ **Packing Speed:** 40 cycles/min
- ▲ **N.W:** 240 kg (arch size 650 × 500mm)
- ▲ **G.W:** 280 kg (arch size 650 × 500mm)

BDM-5115BP

HIGH SPEED FULLY AUTOMATIC STRAPPING MACHINE WITH TOP PRESSER



BDM-5119BP



BDM-5112BP

Arch Size mm (✓ is optional)

BDM-5115BP, BDM-5119BP (5, 6, 9mm PP Strap)

H \ W	650	850	1050	1250	1650
400		✓			
500	standard	✓		✓	✓
600		✓			
800		✓	✓	✓	
1000			✓	✓	

BDM-5112BP (12 mm PP Strap)

H \ W	650	850	1050	1250	1650
400		✓			
500	standard				✓
600		✓	✓	✓	
800		✓	✓	✓	
1000		✓	✓	✓	

Features:

- Speed up to 65cycles/min
- DC brushless motor
- Toolless maintenance
- Belt transport,with top presser
- Touch screen, fault warning function
- With Sensor strapping
- Independent dispenser release switch,easy to feed strap



BDM-5115BP

SPECIFICATION

- ▲ **Power Supply:** 110V, 220V, 230V 50/60Hz 1PH 1.0kW, 220V, 380V, 400V 50/60Hz 3PH 1.0kW
- ▲ **Tension Range:** 0~45 kg
- ▲ **Applicable PP Strap:** Width 5mm~6mm, Thickness 0.5~0.8mm
- ▲ **Applicable PP Strap Spool:** Inner dia. 200~210mm, Outer dia. 400~450mm, Width 170~190 mm
- ▲ **Working Table Height:** ≥ 850 mm
- ▲ **Machine Dimension:** L1480 × W730 × H1980mm
- ▲ **Packing Measurement:** L1600 × W800 × H2100mm
- ▲ **Packing Speed:** 65 cycles/min
- ▲ **N.W:** 270 kg (arch size 650 × 500mm)
- ▲ **G.W:** 310 kg (arch size 650 × 500mm)

BDM-3115BP

FULLY AUTOMATIC STRAPPING MACHINE WITH TOP PRESSER



Arch Size mm (✓ is optional)

BDM-3115BP, BDM-3119BP (5, 6, 9mm PP Strap)

H \ W	650	850	1050	1250	1650
400		✓			
500	standard	✓		✓	✓
600		✓			
800		✓	✓	✓	
1000			✓	✓	

BDM-3112BP (12 mm PP Strap)

H \ W	650	850	1050	1250	1650
400		✓			
500	standard				✓
600		✓	✓	✓	
800		✓	✓	✓	
1000		✓	✓	✓	

Features:

- Speed 30cycles/min
- Belt transport,with top presser
- DC brush motor
- Auto strap feeding, auto strap ejector



BDM-3115BP

SPECIFICATION

- ▲ **Power Supply:** 110V, 220V, 230V 50/60Hz 1PH 1.0kW, 220V, 380V, 400V 50/60Hz 3PH 1.0kW
- ▲ **Tension Range:** 0~45 kg **Packing Speed:** 30 cycles/min
- ▲ **Applicable PP Strap:** Width 5mm~6mm, Thickness 0.5~0.8mm
- ▲ **Applicable PP Strap Spool:** Inner dia. 200~210mm, Outer dia. 400~450mm, Width 170~190mm
- ▲ **Working Table Height:** ≥850mm
- ▲ **Machine Dimension:** L1480 × W730 × H1980mm **N.W:** 270 kg (arch size 650 × 500mm)
- ▲ **Packing Measurement:** L1600 × W800 × H2100mm **G.W:** 310 kg (arch size 650 × 500mm)

BDM-3115R

FULLY AUTOMATIC STRAPPING MACHINE



BDM-3119R



BDM-3112R

Arch Size mm (✓ is optional)

BDM-3115R, BDM-3119R (5, 6, 9 mm PP Strap)

H \ W	550	650	850	1050	1250	1650
400			✓			
500			✓		standard	✓
600			✓	✓		
800			✓	✓	✓	
1000				✓	✓	

BDM-312R (12mm PP Strap)

H \ W	650	850	1050	1250	1650
400		✓			
500				standard	✓
600		✓	✓	✓	
800		✓	✓	✓	
1000		✓	✓	✓	

Features:

- Speed 30 cycles/min
- Roller transport
- Auto strap feeding, auto strap ejector
- Optional high-grade configuration: BDM-5115R



BDM-3115R

SPECIFICATION

- ▲ **Power Supply:** 110V, 220V, 230V 50/60Hz 1PH 1.0kW, 220V, 380V, 400V 50/60Hz 3PH 1.0kW
 - ▲ **Tension Range:** 0-45 kg
 - ▲ **Applicable PP Strap:** Width 5mm-6mm, Thickness 0.5-0.8 mm
 - ▲ **Applicable PP Strap Spool:** Inner dia. 200-210mm, Outer dia. 400-450mm, Width 170-190mm
 - ▲ **Working Table Height:** ≥850mm
 - ▲ **Machine Dimension:** L1520 × W680 × H1500mm
 - ▲ **Packing Measurement:** L1600 × W800 × H1600mm
- Packing Speed:** 30 cycles/min
- N.W:** 250 kg (arch size 1250 × 500mm)
- G.W:** 300 kg (arch size 1250 × 500mm)

BDM-5115S

HIGH SPEED AUTOMATIC STRAPPING MACHINE (SIDE)



BDM-509S



BDM-512S

Arch Size mm

BDM-5115S, BDM-5119S (5, 6, 9mm PP strap)

H \ W	650	850	1050	1250	1650
400		√			
500		√		√	√
600	standard	√			
800		√	√	√	
1000			√	√	

BDM-5112S (12 mm PP Strap)

H \ W	650	850	1050	1250	1650
400		√			
500					√
600	standard	√	√	√	
800		√	√	√	
1000		√	√	√	

Features:

- Side seal
- Speed up to 65cycles/min
- DC brushless motor
- Toolless maintenance
- Touch screen operation, fault warning function
- Operation plate with sensor
- Working table height adjustable



BDM-5115S

SPECIFICATION

▲ **Power Supply:** 110V, 220V, 230V 50/60Hz 1PH 0.6kW

▲ **Tension Range:** 0~45 kg

Packing Speed: 65 cycles/min

▲ **Applicable PP Strap:** Width 5mm~6mm, Thickness 0.5~0.8mm

▲ **Applicable PP Strap Spool:** Inner dia. 200~210mm, Outer dia. 400~450mm, Width 170~190mm

▲ **Working Table Height:** 540±80mm (adjustable)

▲ **Machine Dimension:** L1540 x W500 x H1672mm

N.W: 245kg (arch size 600 x 650mm)

▲ **Packing Measurement:** L1640 x W600 x H1822mm

G.W: 280kg (arch size 600 x 650mm)

BDM-A31S

STAINLESS STEEL SEMI-AUTOMATIC STRAPPING MACHINE



Application:

This machine is a side seal semi-automatic strapping machine. It is the ideal solution for moisture environments, such as seafood, meat, vegetables and so on.

Features:

- Entire machine made by stainless steel
- Compact strapping head (change to the square cutter, the heating plate widen to 20mm)
- New generation of the PCB program



BDM-A31S	SPECIFICATION
▲ Power Supply: 110V, 220V, 230V 50/60Hz 1PH 0.25kW	
▲ Tension Range: 3-45kg	Packing Speed: ≤3seconds/strap
▲ Applicable PP Strap: Width 5-15mm, Thickness 0.5-0.85mm	
▲ Applicable PP Strap Spool: Inner dia. 200-210mm, Outer dia. 400-500mm, Width 160-190mm	
▲ Working Table Height: 730 mm (adjustable)	
▲ Machine Dimension: L850 x W550 x H730mm	N.W: 80 kg
▲ Packing Measurement: L870 x W560 x H780mm	G.W: 90 kg

BDM-3115RP+BDM-LX51111

CORRUGATED BUNDLE SQUARING & STRAPPING SYSTEM



Arch Size mm (✓ is optional)

BDM-3115RP, BDM-3119RP, BDM-3112RP

(5mm, 6mm, 9mm, 12mm PP Strap)

H \ W	550	650	850	1050	1250	1450
400						
500				✓	standard	✓
600					✓	
800						
1000						

Features:

- Speed 13 packs/min
- Corrugated strapping machine BDM-3115RP
- 4-side squaring bundle control BDM-LX51111, bundle turner for corrugated carton is optional
- Optional high-grade configuration: BDM-5115RP

BDM-3115RP

SPECIFICATION

- ▲ **Power Supply:** 220V 50/60Hz 1PH 1.0kW
- ▲ **Tension Range:** 0~45kg
- ▲ **Applicable PP Strap:** width 5mm 6mm thickness 0.5~0.8mm
- ▲ **Applicable PP Strap Spool:** inner dia. 200~210mm, Outer dia. 400~450mm, Width 170~190mm
- ▲ **Working Table Height:** 850mm
- ▲ **Machine Dimension:** L1520 × W680 × H2000mm
- ▲ **Packing Measurement:** L1600 × W800 × H2100mm
- ▲ **Air pressure:** 10L/cycle
- ▲ **Packing Speed:** 13 packs/min
- ▲ **N.W:** 280 kg (arch size 1250 × 500mm)
- ▲ **G.W:** 330 kg (arch size 1250 × 500mm)

BDM-LX51111

SPECIFICATION

- ▲ **Power Supply:** 380V 50/60Hz 3PH 1.0kW
- ▲ **Speed:** 13 packs/min
- ▲ **Working Table Height:** 850mm
- ▲ **Machine Dimension:** L1900 × W2050 × H1470mm
- ▲ **Packing Measurement:** L2100 × W1950 × H1500mm
- ▲ **N.W:** 780 kg (arch size 1250 × 500mm)
- ▲ **G.W:** 820 kg (arch size 1250 × 500mm)

BDM-3115RPD+BDM-LX51111

CORRUGATED BUNDLE SQUARING & STRAPPING SYSTEM



Arch Size mm (✓ is optional)

BDM-3115RPD, BDM-3119RPD, BDM-3112RPD
(5mm, 6mm, 9mm, 12mm PP Strap)

H \ W	550	650	850	1050	1250	1450
400						
500				✓	standard	✓
600					✓	
800						
1000						

Features:

- Speed 18 packs/min
- Double arch strapping machine BDM-3115RPD
- 4-side squaring bundle control BDM-LX51111, bundle turner for corrugated carton is optional
- Optional high-grade configuration: BDM-5115RPD

BDM-3115RPD

SPECIFICATION

- ▲ **Power Supply:** 220V 50/60Hz 1PH 2.4kW
- ▲ **Tension Range:** 0~45kg
- ▲ **Applicable PP Strap:** Width 5mm~6mm, Thickness 0.5~0.8mm
- ▲ **Applicable PP Strap Spool:** Inner dia. 200~210mm, Outer dia. 400~450mm, Width 170~190mm
- ▲ **Working Table Height:** ≤920mm
- ▲ **Machine Dimension:** L2040 × W1190 × H2100mm
- ▲ **Packing Measurement:** L2140 × W1310 × H2250mm
- ▲ **Air pressure:** 10 L/cycle
- ▲ **Packing Speed:** 18 packs/min
- ▲ **N.W:** 380 kg (arch size 1250×500mm)
- ▲ **G.W:** 440 kg (arch size 1250×500mm)

BDM-LX51111

SPECIFICATION

- ▲ **Power Supply:** 380V 50/60Hz 3PH 1.0kW
- ▲ **Speed:** 18 packs/min
- ▲ **Working Table Height:** 850mm
- ▲ **Machine Dimension:** L1900 × W2050 × H1470mm
- ▲ **Packing Measurement:** L2100 × W1950 × H1500mm
- ▲ **N.W:** 780 kg (arch size 1250 × 500mm)
- ▲ **G.W:** 820 kg (arch size 1250 × 500mm)

BDM-3115RP+BDM-LX5111ID

CORRUGATED BUNDLE SQUARING & STRAPPING SYSTEM



Arch Size mm (✓ is optional)

BDM-3115RP, BDM-3119RP, BDM-3112RP
(5mm, 6mm, 9mm, 12mm PP Strap)

H \ W	550	650	850	1050	1250	1450
400						
500				✓	standard	✓
600					✓	
800						
1000						

Features:

- Speed 20 packs/min
- Double units strapping machines BDM-3115RP
- Squaring bundle control with double channels BDM-LX5111ID
- Optional high-grade configuration: BDM-5115RP

BDM-3115RP

SPECIFICATION

- ▲ **Power Supply:** 220V 50/60Hz 1PH 1.0kW **Air pressure:** 10 L/cycle
- ▲ **Tension Range:** 0~45kg **Packing Speed:** 20 packs/min
- ▲ **Applicable PP Strap:** width 5mm 6mm thickness 0.5~0.8mm
- ▲ **Applicable PP Strap Spool:** inner dia. 200 210mm outer dia. 400 450mm width 170 190mm
- ▲ **Working Table Height:** 850mm
- ▲ **Machine Dimension:** L1520 × W680 × H2000mm **N.W:** 280 kg (arch size 1250 × 500mm)
- ▲ **Packing Measurement:** L1600 × W800 × H2100mm **G.W:** 330 kg (arch size 1250 × 500mm)

BDM-LX5111ID

SPECIFICATION

- ▲ **Power Supply:** 380V 50/60Hz 3PH 1.6kW
- ▲ **Speed:** 20 packs/min
- ▲ **Working Table Height:** 850~950mm
- ▲ **Machine Dimension:** L4650 × W1720 × H1300mm **N.W:** 1700 kg (arch size 1250 × 500mm)
- ▲ **Packing Measurement:** L2700 × W1800 × H1500mm **G.W:** 1850 kg (arch size 1250 × 500mm)
& L2000 × W1800 × H1500mm

BZ-1115A

FULLY AUTOMATIC HORIZONTAL STRAPPING MACHINE



Features:

- One to multi-cycles horizontal pallet strapping
- Suitable for the large products, cooperate with BZ-1115B
- Hot welding at the side

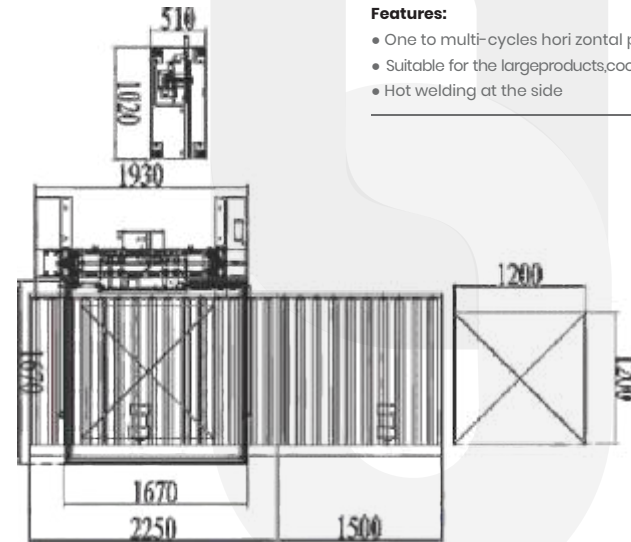

BZ-1115A	SPECIFICATION
▲ Power Supply: 380V 50/60Hz 3PH 3.1kW	Air pressure: 0.4-0.6MPa
▲ Tension Range: 0-90kg (adjustable)	Packing Speed: <15 seconds/cycle
▲ Applicable PP Strap: Width 9-15 (±0.1) mm, Thickness 0.55-1.0 (±0.1) mm	
▲ Applicable PP Strap Spool: Inner dia. 200-210mm, Outer dia. 400-500mm, Width 160-180	
▲ Machine Dimension: L1930 × W3240 × H2800mm	N.W: 350kg (arch size W1500mm×H1500mm)
▲	

BZ-1115AH

FULLY AUTOMATIC HORIZONTAL STRAPPING MACHINE (HEAVY)



Features:

- One to multi-cycles horizontal pallet strapping
- High-tension, suitable for the heavy products

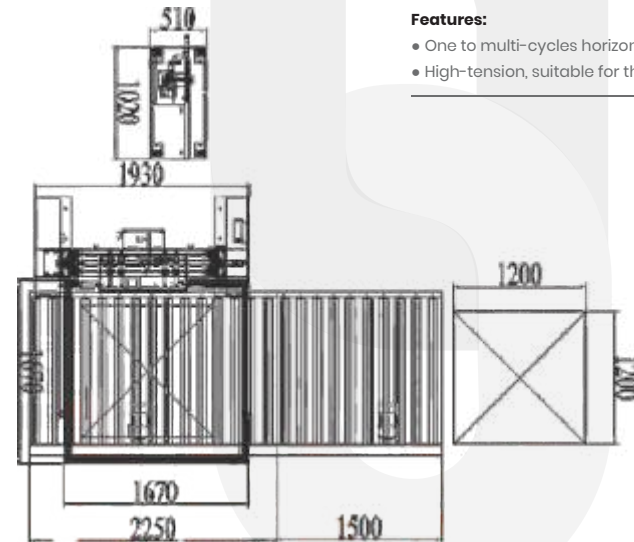

BZ-1115AH	SPECIFICATION
▲ Power Supply: 380V 50/60Hz 3PH 3.1kW	Air pressure: 0.4 ~0.6MPa
▲ Tension Range: 20~250kg (adjustable)	Packing Speed: ≤15 seconds/cycle
▲ Applicable PET Strap: Width 9-15 (±0.1) mm, Thickness 0.55-1.0 (±0.1) mm	
▲ Applicable PET Strap Spool: Inner dia. 406mm, Outer dia. 600mm, Width 190mm	
▲ Machine Dimension: L1930 × W3240 × H2800mm	N.W: 350kg (arch size W1500mm × H1500mm)
▲	

BZ-1115B

FULLY AUTOMATIC VERTICAL STRAPPING MACHINE



Features:

- One to multi-cycles vertical pallet strapping
- Top presser is optional
- Hot welding at the side

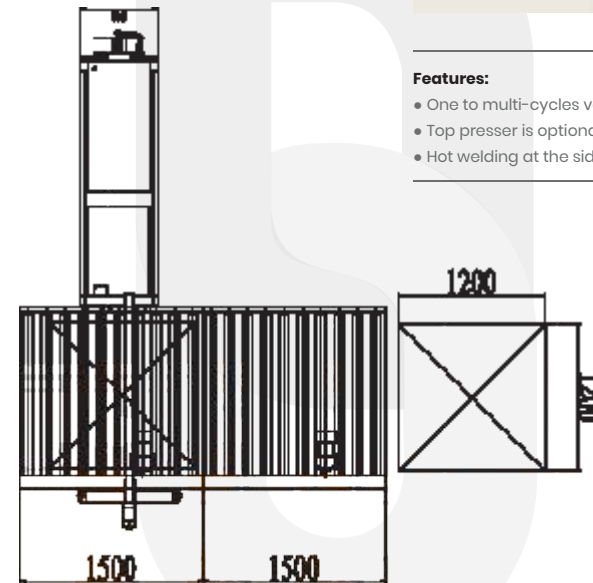

BZ-1115B

SPECIFICATION

▲ **Power Supply:** 380V 50/60Hz 3PH 1.6kW

Air pressure: 0.4 ~0.6 MPa

▲ **Applicable PP Strap:** Width 9-15 (±0.1) mm, Thickness 0.55-1.0 (±0.1) mm

▲ **Applicable PP Strap Spool:** Inner dia. 200-210mm, Outer dia. 400-500mm, Width 160-180mm

▲ **Machine Dimension:** L1415mm × W845mm × H2630mm **N.W:** 350kg (arch size W1500×H2000mm)

▲

BZ-1115BH

FULLY AUTOMATIC VERTICAL STRAPPING MACHINE (HEAVY)

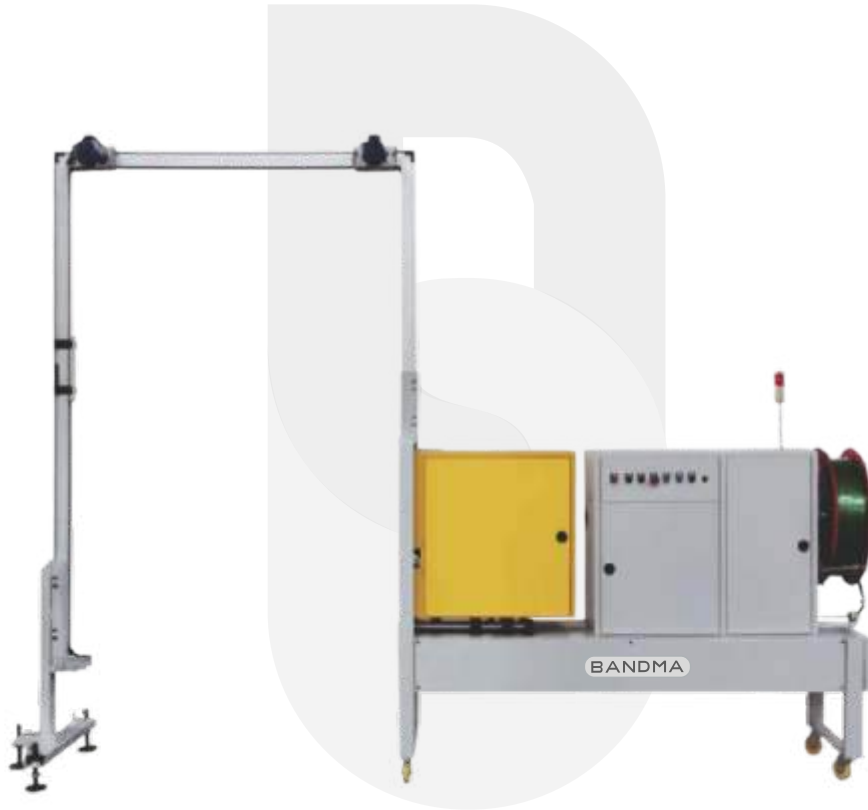

Features:

- One to multi-cycles vertical pallet strapping
- High-tension, Suitable for the heavyproducts

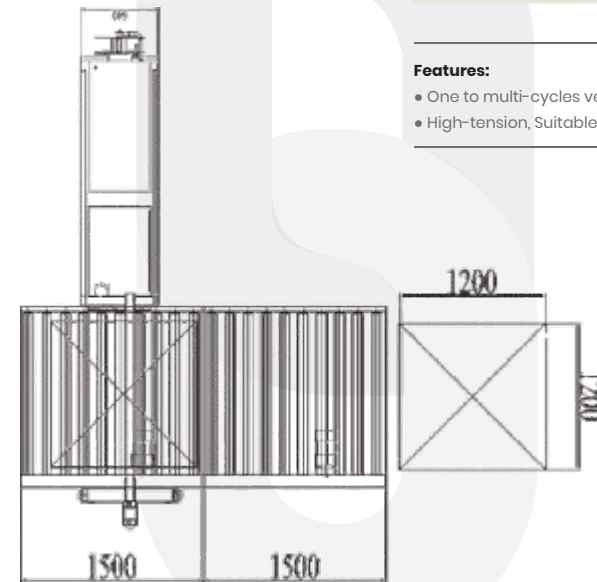

BZ-1115BH	SPECIFICATION
▲ Power Supply: 380V 50/60Hz 3PH 1.6kW	Air pressure: 0.4 ~0.6MPa
▲ Tension Range: 20~250kg (adjustable)	Packing Speed: <15 seconds/cycle
▲ Applicable PET Strap: Width 9~15 (±0.1) mm, Thickness 0.55~1.0 (±0.1) mm	
▲ Applicable PET Strap Spool: Inner dia. 406mm, Outer dia. 600mm, Width 190mm	
▲ Machine Dimension: L1415mm×W845mm×H2630mm N.W.: 350kg (arch sizeW1500mm×H2000mm)	
▲	

BZ-1115C

FULLY AUTOMATIC VERTICAL STRAPPING MACHINE WITH TOP PRESSER



Features:

- Vertical pallet strapping with top presser
- Hot welding on the top (PET strap)

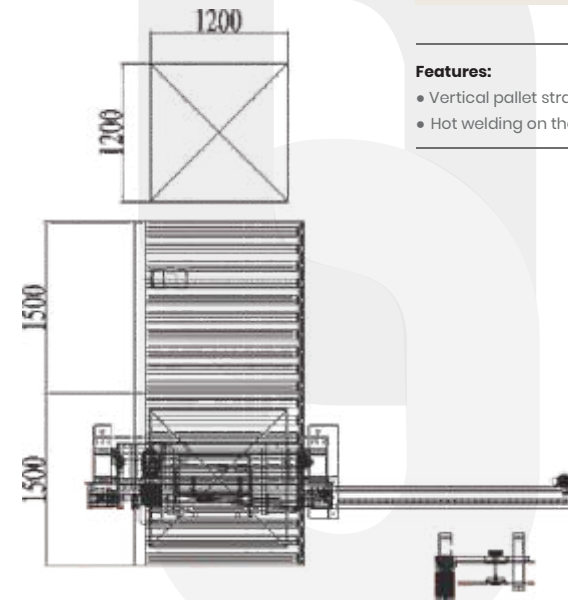

BZ-1115C

SPECIFICATION

- | | |
|---|---|
| ▲ Power Supply: 380V 50/60Hz 3PH 4.0kW | Air pressure: 0.4 ~0.6MPa |
| ▲ Tension Range: 20~250kg (adjustable) | Packing Speed: ≤15 seconds/cycle |
| ▲ Applicable PET Strap: Width 9~19 (±0.1) mm, Thickness 0.55~1.0 (±0.1) mm | |
| ▲ Applicable PET Strap Spool: inner dia. 406mm, outer dia. 600mm, width 190mm | |
| ▲ Machine Dimension: L4250mm×W800mm×H3300mm N.W: 800kg (arch sizeW1500mm×H1800mm) | |
| ▲ | |

FULLY AUTOMATIC PACKING LINE 1

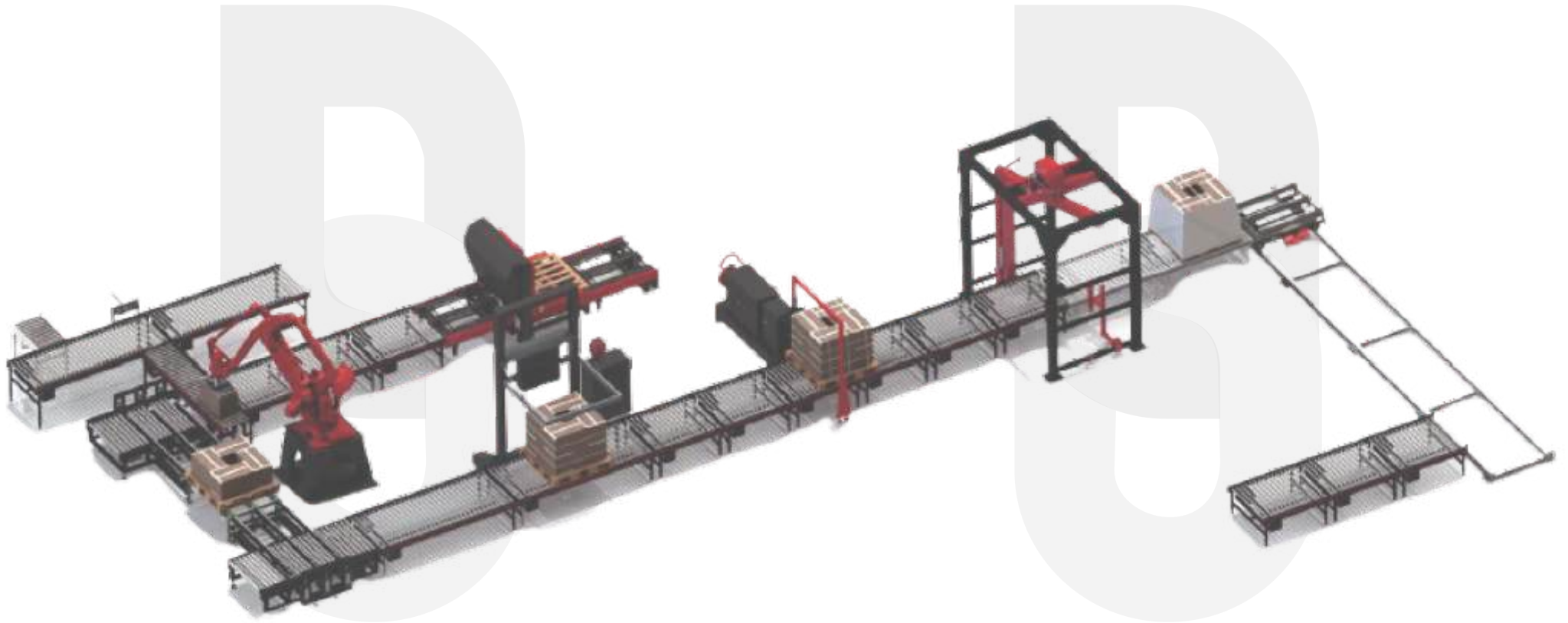

FULLY AUTOMATIC PACKING LINE 2

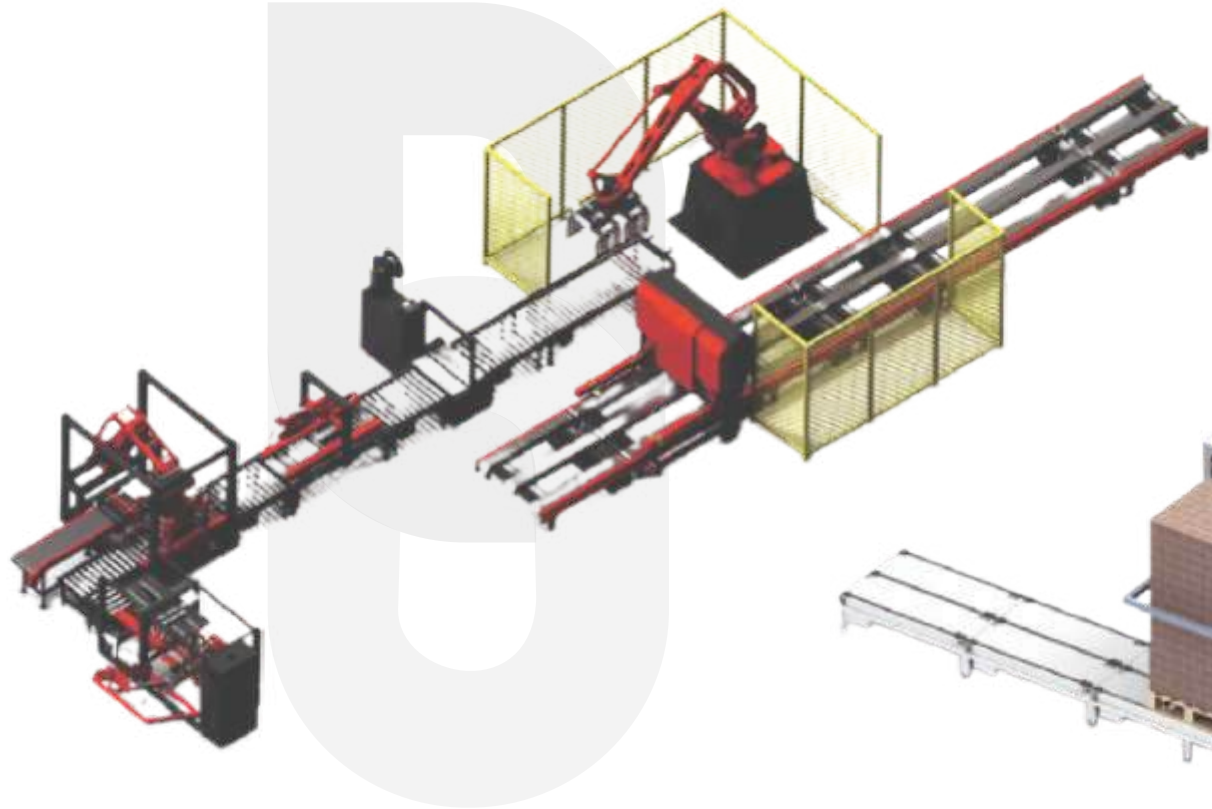

FULLY AUTOMATIC PACKING LINE 3

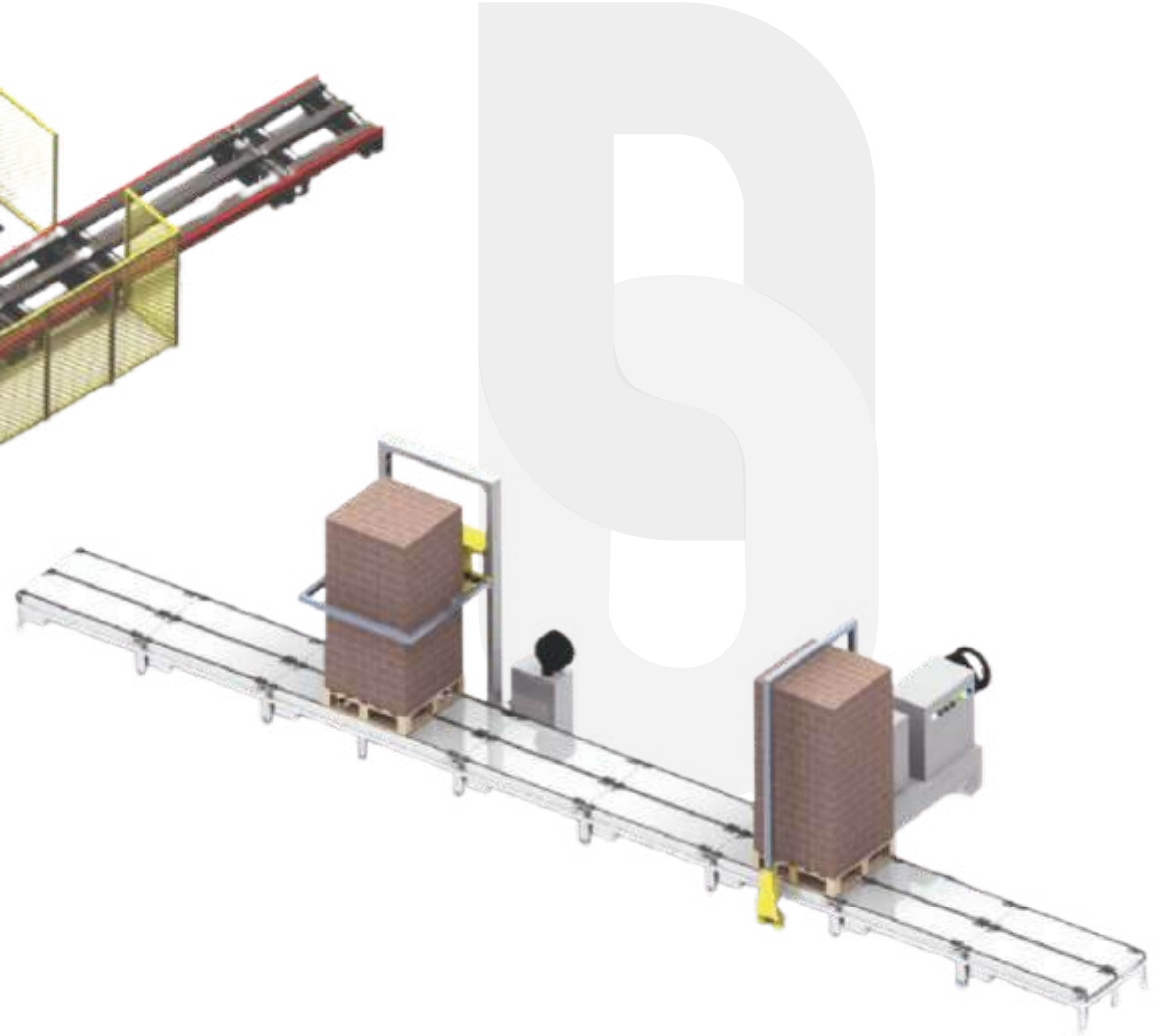

BDAG12

AUTOMATIC BANDING MACHINE



External dispenser

Arch Size mm (✓ is optional)

30mm Paper/OPP film, 20mm has one size only: 460x200mm

H \ W	460	600	--	--	--	--
200	standard	✓				
300	✓					
400	✓	✓				
500						
600		✓				

Features:

- Conform with CE, with power failure protection, no-action protection function
- DC 24V safety voltage
- Touch screen and button operation
- Parameter settings on touch screen, with 6 languages
- Every port has a detection function, easy to get information



BDAG12 SPECIFICATION

- ▲ **Power Supply:** 110-120/200-240V 50/60Hz 1PH 0.25kW
- ▲ **Tension Range:** ≤5kg (adjustable) **Packing Speed:** 26 cycles/min
- ▲ **Applicable Band:** Paper/OPP film **Band Width:** Standard 30mm (20mm is optional)
- ▲ **Applicable Band Spool:** Refer to following material specification
- ▲ **Working Table Height:** 245mm
- ▲ **Machine Dimension:** L650×W360×H480mm **N.W:** 40 kg (arch size 460×200mm)
L650×W360×H1140mm **N.W:** 75 kg (external dispenser, arch size 460×200mm)
- ▲ **Packing Measurement:** L680×W400×H630mm **G.W:** 50 kg (arch size 460 × 200mm)
L680×W470×H1290mm **G.W:** 95 kg (external dispenser, arch size 460 × 200mm)

Description	Band width	Band thickness	Roll length	Inner dia	Outer dia
Paper	20/30mm	0.12mm	200m	Ø40mm	Ø180mm (inner dispenser)
					Max Ø<380mm (external dispenser)
OPP film	20/30mm	0.12mm	200m	Ø42mm	Ø160mm (inner dispenser)
					Max Ø<380mm (external dispenser)

BDAG13

AUTOMATIC BANDING MACHINE



Arch Size mm (✓ is optional)

12 mm / OPP film

H \ W	220	360	--
170	✓		
260		✓	

Features:

- Internal is DC 24V safe voltage.
- Parameters can be directly set on the touch screen
- This machine has the function of each port detection
- This machine has the function of production record It can be accumulated and be cleared.



BDAG13 SPECIFICATION

- ▲ **Power Supply:** 110~120/200~240V 50/60Hz 1PH 0.25kW
- ▲ **Tension Range:** ≤5kg(adjustable) **Packing Speed:** 26cycles/min (arch size 220 × 170mm)
- ▲ **Applicable Band:** OPP film **Band Width:** Standard 12mm
- ▲ **Applicable Band Spool:** Refer to following material specification
- ▲ **Working Table Height:** 215mm
- ▲ **Machine Dimension:** L380 × W280 × H415mm **N.W:** 18 kg (arch size 220 × 170mm)
L520 × W280 × H505mm **N.W:** 22 kg (arch size 360 × 260mm)
- ▲ **Packing Measurement:** L440×W340×H550mm **G.W:** 28 kg (arch size 220 × 170mm)
L580×W340×H640mm **G.W:** 35 kg (arch size 360 × 260mm)

Description	Band width	Band thickness	Roll length	Inner dia	Outer dia
OPP film	12 mm	0.12 mm	150 m	Ø40 mm	Ø160 mm

PACKAGING MATERIALS CHAPTER





PP Strap

SS Strap							
Model	5047	8045	9055	1006	1106	1206	
WidthxThickness (mm)	5x0.47	8x0.45	9x0.55	10x0.6	11x0.6	12x0.6	
Core diameter (mm)	200x190	200x190	210x178	210x178	210x178	210x178	
Length (m)	7000	4500	4000	3600	3000	3000	
Tensile Strength (kg)	52	80	85	80	100	100	
S Strap							
Model	5047	9055	1106	1206			
WidthxThickness (mm)	5x0.47	9x0.55	11x0.6	12x0.6			
Core diameter (mm)	200x190	210x178	210x178	210x178			
Length (m)	7000	4000	3000	3000			
Tensile Strength (kg)	52	70	90	100			

*It is used for small frame strapping machine. Suitable for light goods.

HS Strap							
Model	5006	9006	1106	1206			
WidthxThickness (mm)	5x0.6	9x0.6	11x0.6	12x0.6			
Core diameter (mm)	200x190 200x175	210x178	210x178	210x178			
Length (m)	6000	3500	3000	3000			
Tensile Strength (kg)	60	70	90	110			

*Standard color:white,red,yellow,black and blue

PP Strap

SH Strap							
Model	1206	1207					
WidthxThickness (mm)	12x0.6	12x0.7					
Core diameter (mm)	210x178	210x178					
Length (m)	2500	2200					
Tensile Strength (kg)	100	120					

*Standard color:white,red,yellow,black and blue

HXH Strap							
Model	1207	12075					
WidthxThickness (mm)	12x0.7	12x0.75					
Core diameter (mm)	210x178	210x178					
Length (m)	2500	2200					
Tensile Strength (kg)	80	90					

*Standard color:white,red,yellow,black and blue

WS Strap optional material SS and S level								
Model	1206	1207	13506	1506	155067	1806	1906	1308
WidthxThickness (mm)	12x0.6	12x0.7	13.5x0.6	15x0.6	15.5x0.67	18x0.6	19x0.6	13x0.8
Core diameter (mm)	210x178	210x180	210x180	210x180	210x180	210x185	210x185	210x180
Length (m)	2500	2000	2200	2000	1800	1800	1700	1500
Tensile Strength (kg)	130	160	160	180	200	190	200	180

HH,HX Strap							
Model	1207	12075	1208	9006			
WidthxThickness (mm)	12x0.7	12x0.75	12x0.8	9x0.6			
Core diameter (mm)	210x178	210x178	210x178	210x175			
Length (m)	2500	2000	1800	3300			
Tensile Strength (kg)	70	90	100	60			

*Standard color:white,red,yellow,black and blue

